

PRODUCT DESCRIPTION

SPECTEC's 5/8" size magnetic pickups are part of a family of modular, rugged and high performance "passive" type speed sensors ranging in size from 3/16" to 3/4" Dia. They feature high output voltage and great configuration diversity to meet a wide range of applications. An integral temperature sensor is available as an option.

SPECIFICATIONS

DC-Coil Type 1: 80 Ω/ 25 mH, 35 Vpp
Resist./Inductance, Type 2: 210 Ω/ 85 mH, 45 Vpp
Output Voltage: Type 4: 1100 Ω/ 450 mH, 170 Vpp
 (When tested at 1000 IPS against 20 pitch, 30 tooth gear at .005" gap, 100k Ohm load. Inductance and output voltage notations are maximum values.)

Magnetization: Standard: 1000 GAUSS, TYP.
 Low Mag: 250 GAUSS, TYP.

Temperature Range: 2T: -100° to 250° F (-73° to 120°C)
 3T: -150° to 330° F (-101° to 165°C)

Pole Piece: Flush, Extended & Chisel Points are available. (Chisel must be oriented parallel with gear tooth.)

Pole Piece Selections: 0014 is shown with the extended pole (EP).
 0018 is shown in the flush pole (FP) version.
 To optimize performance please note gear pitch/pole piece recommendations:

GEAR PITCH	POLE PIECE
≤ 36 DP (Module 0.7)	EP, CP10
≤ 26 DP (Module 0.98)	EP93
≤ 24 DP (Module 1.06)	EP106, CP45 EP125, FP
≤ 12 DP (Module 2.11)	EP188
≤ 5 DP (Module 5.1)	EP250

Construction: 303/304 S.S., Solid Epoxy Encapsulation.

CE-Compliance: EN55011, EN50022-2

OPTIONS:

For different length, material of construction, configuration, special pole-piece types, thread size, hermetically sealed, precision custom magnetization, connector and/or cable termination, please contact factory.

For CL 1, Div I & II hazardous location, Intrinsically Safe, and Non Incendive versions; please refer to IS40 and N40.

0014 5/8-18

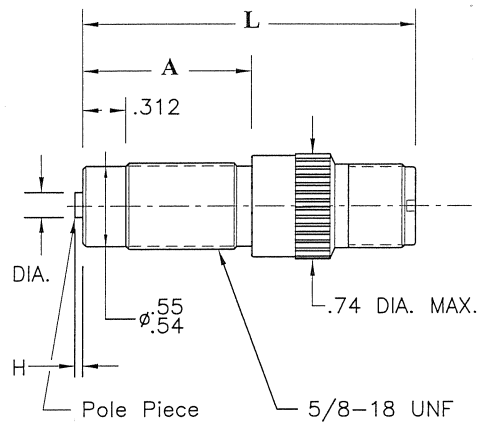

0018B 5/8-18 SHOWN WITH SHIELDED CABLE "Lx"

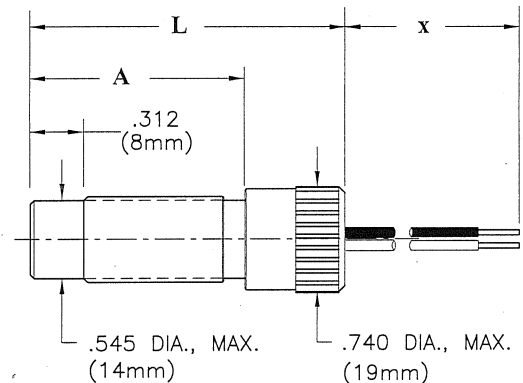

0018 5/8-18 SHOWN WITH SHIELDED CABLE "LSx"

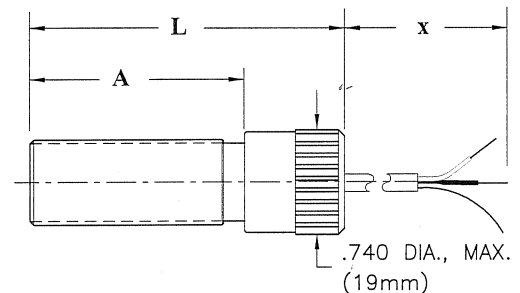

0014-xx MAGNETIC VRS SPEED SENSOR, WITH .312" THREAD RELIEF, CONNECTOR TYPE
 0018B-xx MAGNETIC VRS SPEED SENSOR
 0018-xx MAGNETIC VRS SPEED SENSOR, KL-TYPE .312" THREAD RELIEF

SPECTEC P/N	Thread	Thread Length	Overall Length with Connector	Coil Type	Pole Piece	Connector	Lead Wire Type X	Temp. Rating
0014-xx	5/8-18			Type1 80Ω	FP (.130 DIA.) EP62 (.062 DIA. x .03 H)			2T
0018B-xx	5/8-18			Power Output	EP93 (.093 DIA. x .03 H)			3T
0018-xx	5/8-18			Type 2 210Ω	EP106 (.106 DIA. x .02 H) EP125 (.125 DIA. x .07 H) EP187 (.187 DIA. x .02 H)			5HT
				Std. Output	EP250 (.250 DIA. x .02 H) CP10 CHISEL (.010 W) CP45 CHISEL (.045 W)			RTD 100 NTC 10
				Type 4 1100Ω High Output				

When ordering, please specify features selected from the above table.

Specific Models:

0014-01	5/8-18	1.43 (36mm)	2.5 (64mm)	80Ω	EP106	MS	N/A	3T
0014-02				210Ω	EP187			
0014-03				1100Ω	EP106			
0014-04				1500Ω	EP160			
0014-05				80Ω	CP45			
0014-06				210Ω				
0014-07				1100Ω				
0014-11	2.5 (64mm)	3.6 (91mm)	80Ω	EP106				
0014-12			210Ω	EP187				
0014-13			1100Ω	EP106				
0018-01		2.13 (54mm)	2.75 (70mm)	1100Ω		N/A	LS 120"	2T
0018-02							LS 168"	
0018-03							LS 276"	
0018B-50		1.43 (36mm)	2.07 (53mm)	210Ω			L 12"	3T

NOTE: THE MANGNETIZATION LEVEL FOR SPECIAL OR LOW MAGNETIC DRAG SENSORS, IS CALLED OUT AS A SUFFIX TO THE PART NUMBER, ie: 0014-xx-300G DESIGNATING A GAUSS LEVEL OF 300. (STANDARD MAGNETIC LEVEL (UP TO 1200G) WILL NOT HAVE A SUFFIX.)