

PRODUCT DESCRIPTION

SPECTEC's Digital RF pickup produces a digital frequency output directly proportional to speed. The internal amplifier provides for constant pulse shaping, signal amplitude, near zero speed performance and good sensitivity (air gap). Internal temperature probes are also available.

For CL 1, Div I & II hazardous location, intrinsically safe, and non-incendive versions; please refer to IS100 and IS101.

SPECIFICATIONS

Vs, Supply Voltage: 7 to 30 Vdc (Std.), or 3.8 to 30 Vdc
 @ ≤ 10 mA See Page 2
 Reverse Polarity Protected

Vo, Signal Out: 0 – 10V (Std.)
 @ ≤ 20 mA sink 0 – 5V (TTL)
 0 – Vs
 (@ ≤ 200 mA for NPN/PNP universal sink/source)

Operating Freq.: Vs = 3.8 - 30VDC: 0.5 to ≤ 5000 Hz
 Vs = 7.0 - 30VDC: 0.5 to ≤ 4000 Hz
 Vs = 11.0 - 30VDC: 0.5 to ≤ 7000 Hz

Air Gap: ≤ .160" (Depending on target mass)

Rise/Fall Time(N.L.): 0.04 μs / 0.18 μs

Temperature Range: 2TE: -40° to 257°F (-40° to 125°C)
 3TE: -49° to 284°F (-45° to 140°C)

Construction: 300 Series stainless steel housing
 Solid epoxy encapsulation

Connectors: See Page 2 for Configurations
 All have Gold Plated Contacts

Lead Wire & Assignments: See Page 2 for Wire & Cable Options
 2TE: PVC, 20-24 AWG (105°C max)
 3TE: TFE, 20 AWG
 Red: Supply (+)
 Black: Common (-)
 White/Green: Signal Out
 Bare: Shield

With NTC type Temp. Probe
 Red (x2)

With RTD type Temp. Probe
 Red (x1)
 Black (x2) Dual black leads for lead wire resistance compensation

Construction: 300 Series stainless steel housing
 Solid epoxy encapsulation

CE-Compliance: EN55011, EN50082-2

Options

For different length, material of construction, configuration, thread sizes, hermetically sealed, precision custom magnetization, connector and/or cable termination, please contact factory.

0097 11/16-24 UNEF

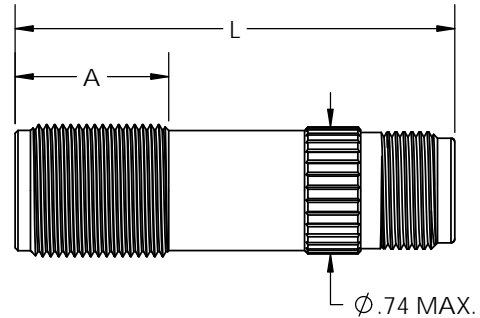

0097H 11/16-24 UNEF

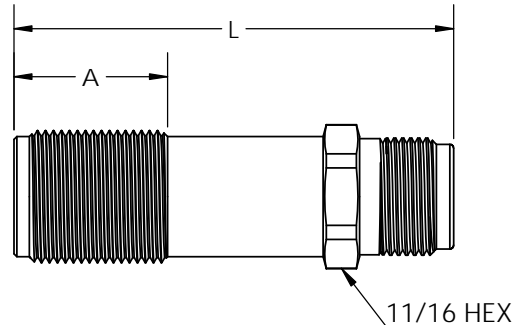

0098 11/16-24 UNEF

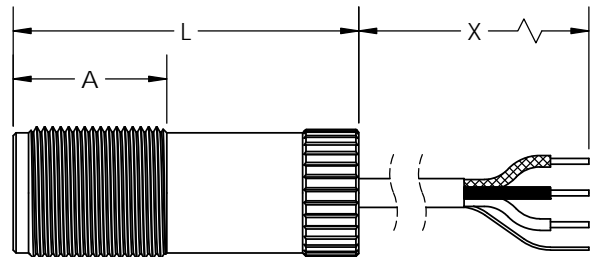

0098X 11/16-24 UNEF with 1/2-14 NPT Male

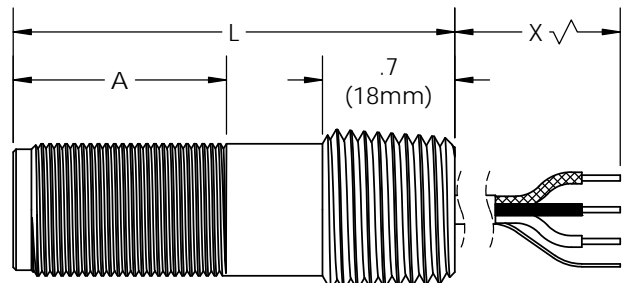

ORDER INFORMATION

STYLE	OPTIONS	THREADS/DIA.								
0097	- <input type="checkbox"/> <input type="checkbox"/> <input type="checkbox"/> <input type="checkbox"/> <input type="checkbox"/>	11/16-24 UNEF								
0097H	- <input type="checkbox"/> <input type="checkbox"/> <input type="checkbox"/> <input type="checkbox"/> <input type="checkbox"/>	11/16-24 UNEF								
Thread (A) & Housing (L) Length:		<table border="1"> <thead> <tr> <th>A</th> <th>L</th> </tr> </thead> <tbody> <tr> <td>0 - 1.1" (28mm)</td> <td>2.75" (70mm)</td> </tr> <tr> <td>1 - 1.3" (33mm)</td> <td>3.0" (76mm)</td> </tr> <tr> <td>2 - 1.3" (33mm)</td> <td>3.5" (89mm)</td> </tr> </tbody> </table>	A	L	0 - 1.1" (28mm)	2.75" (70mm)	1 - 1.3" (33mm)	3.0" (76mm)	2 - 1.3" (33mm)	3.5" (89mm)
A	L									
0 - 1.1" (28mm)	2.75" (70mm)									
1 - 1.3" (33mm)	3.0" (76mm)									
2 - 1.3" (33mm)	3.5" (89mm)									

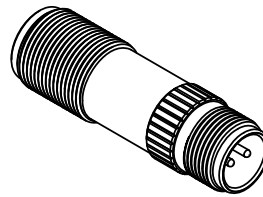

Connector Pinouts

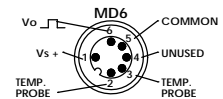
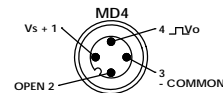
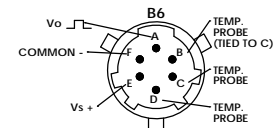
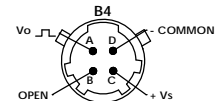
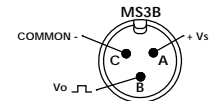
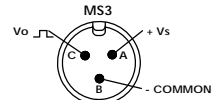

Face: 0 - Epoxy sealed face (for greater sensitivity)
1 - Stainless steel face (Blindshell, for harsh environments)

Vo, Vs:

- 1 - 0 - 5V, NPN (6 kΩ), Vs: 7 - 30 VDC
- 2 - 0 - 10V, NPN (6 kΩ), Vs: 11 - 30 VDC
- 3 - 0 - Vs, NPN (6 kΩ), Vs: 7 - 30 VDC
- 4 - 0 - Vs, NPN (OC), Open collector, Vs: 7 - 30 VDC
- 5 - 0 - Vs, NPN (OC), Open collector, Vs: 3.8 - 30 VDC
- 7 - 0 - Vs, NPN (6 kΩ), Vs: 3.8 - 30 VDC
- 8 - 0 - 5V, NPN (6 kΩ), Vs: 3.8 - 30 VDC
- 9 - 0 - Vs, NPN/PNP Universal sink/source, Vs 7 - 30 Vdc (@ ≤ 200mA)
- A - LED, 0 - 5V, NPN (6 kΩ), Vs: 7 - 30 VDC
- B - LED, 0 - 10V, NPN (6 kΩ), Vs: 11 - 30 VDC
- C - 0 - 5V, NPN (6 kΩ), Vs: 7 - 30 VDC, 50 kHz Carrier
- D - LED, 0 - Vs, PNP (OC), Vs: 7 - 30 VDC
- E - LED, 0 - Vs, NPN (OC), Vs: 7 - 30 VDC

Temperature Range & Probe:

- 1 - 2TE: -40° to 257°F (-40° to +125°C)
- 2 - 3TE: -49° to 284°F (-45° to +140°C)
- A - 3TE: -49° to 284°F (-45° to +140°C) with RTD100Ω
- B - 2TE: -40° to 257°F (-40° to +125°C) with RTD100Ω
- C - 2TE: -40° to 257°F (-40° to +125°C) with NTC10kΩ
- D - 3TE: -49° to 284°F (-45° to +140°C) with NTC10kΩ

Connector:

- 1 - MS3: 3 Pin MS3106-10SL-3P (See Bulletin 3000)
- 3 - MS3B: 3 Pin MS3102-10SL-3P (See Bulletin 3000)
- 4 - B4: 4 Pin Bayonet, MS3113-H8A-4P (See Bulletin 3001)
- 5 - B6: 6 Pin Bayonet, MS3111-H10A-6P (See Bulletin 3001)
- 7 - MD4: 4 Pin Micro DIN (See Bulletin 3005)
- 8 - MD6: 6 Pin Micro DIN (See Bulletin 3005)

STYLE	OPTIONS	THREADS/DIA.						
0098	- <input type="checkbox"/> <input type="checkbox"/> <input type="checkbox"/> <input type="checkbox"/> <input type="checkbox"/>	11/16-24 UNEF						
Thread (A) & Housing (L) Length:		<table border="1"> <thead> <tr> <th>A</th> <th>L</th> </tr> </thead> <tbody> <tr> <td>1 - 1.10" (28mm)</td> <td>2.25" (57mm)</td> </tr> <tr> <td>2 - 1.30" (33mm)</td> <td>3.0" (76mm)</td> </tr> </tbody> </table>	A	L	1 - 1.10" (28mm)	2.25" (57mm)	2 - 1.30" (33mm)	3.0" (76mm)
A	L							
1 - 1.10" (28mm)	2.25" (57mm)							
2 - 1.30" (33mm)	3.0" (76mm)							

SAME AS ABOVE

Lead Wire(X):

- 2 - 2' (.6m) Single Leads
- 7 - 3' (1m) Shielded Cable
- 9 - 10' (3m) Shielded Cable
- A - 20' (6m) Shielded Cable

Note: Cable Shielding is not connected to sensor, and is intended to be connected to the instrument ground.

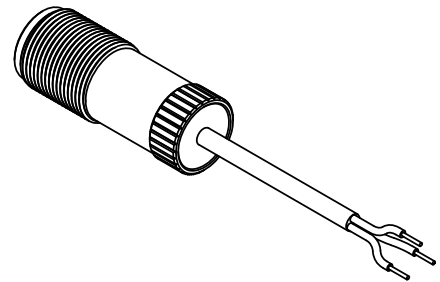

STYLE	OPTIONS	THREADS/DIA.						
0098X	- <input type="checkbox"/> <input type="checkbox"/> <input type="checkbox"/> <input type="checkbox"/> <input type="checkbox"/>	11/16-24 UNEF with 1/2-14 NPT Female						
Thread (A) & Housing (L) Length:		<table border="1"> <thead> <tr> <th>A</th> <th>L</th> </tr> </thead> <tbody> <tr> <td>1 - .70" (18mm)</td> <td>1.9" (48mm)</td> </tr> <tr> <td>2 - 1.3" (33mm)</td> <td>2.6" (66mm)</td> </tr> </tbody> </table>	A	L	1 - .70" (18mm)	1.9" (48mm)	2 - 1.3" (33mm)	2.6" (66mm)
A	L							
1 - .70" (18mm)	1.9" (48mm)							
2 - 1.3" (33mm)	2.6" (66mm)							

SAME AS ABOVE

